

The information disclosed herein is the property of the originator who reserves all patent, design, proprietary, manufacturing, use and sales rights thereto, except for the rights expressly granted to others. This document shall not be reproduced nor shall the information contained within be used by or disclosed to others except as expressly authorized by the originator. ©

Revision  
Letter

Change  
Description

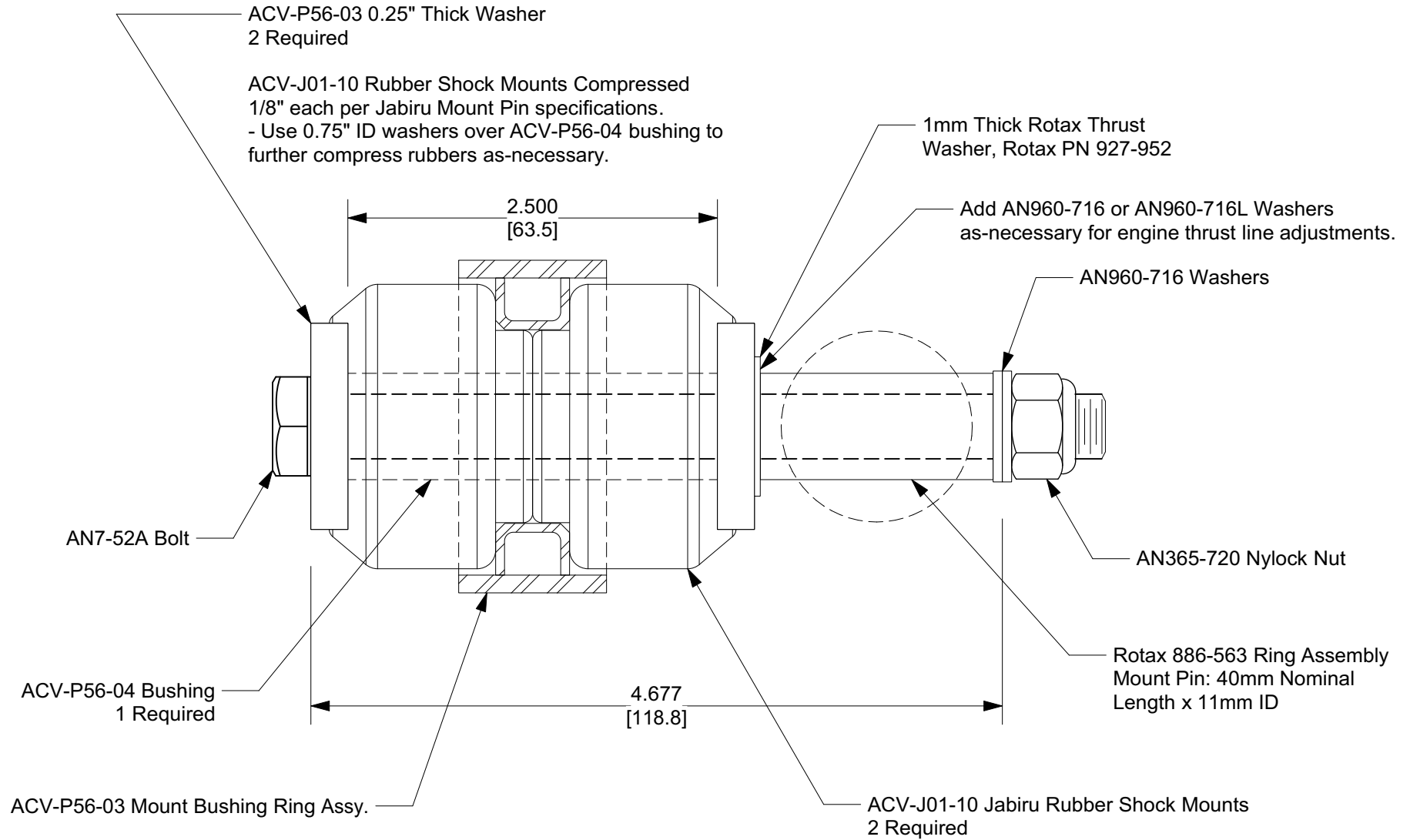

<b>AeroConversions</b>		
<b>Rotax Mount Ring Installation Detail</b>		
Drawing Scale	Drawing Number	Revision
FULL	ACV-P56	N/C